

DEUTZ TCD 9.0 Power Pack

200 – 304 kW / 270 - 413 hp at 2100 min-1/rpm ■ EU Stage V, US EPA Tier 4 Final

**TCD
9.0**



The engine company.

DEUTZ Factory-Built Power Packs

- DEUTZ factory-built Power Packs are compact, ready-to-install engine solutions for mobile machinery.
- Designed for use in the construction, agricultural and industrial markets, each Power Pack is fully tested and validated to offer a robust and completely integrated power package.
- Not only are DEUTZ Power Packs easy to install, but they also offer the industry's lowest installed and operational costs, and they come with the same exclusive warranty as new DEUTZ engines.
- DEUTZ TCD 9.0 L4 Power Packs are available in ready-to-run, pedestal-mounted and open-configuration packages and are supported by a large range of options and accessories.
- When installed in mobile machinery, these Power Packs offer features for regulated and unregulated markets with identical performances, cooling system requirements and interfaces. As a result, customers can use the same device design to meet different emission standards.
- The robust design of the TCD 9.0 L4 is especially suited for the harshest requirements.
- The TCD 9.0 L4 Power Packs feature a proven and robust water-cooled, balanced, 4-cylinder inline diesel engine.
- The TCD 9.0 L4 Power Packs include a mounted cooling-and-guard package, and the engine can be equipped with a suction or pusher fan.
- These engines meet the requirements of EU Stage V and US EPA Tier 4 with selective catalytic reduction (SCR). A version is also available for export to lower-regulated countries (LRC).
- DEUTZ factory-built Power Packs offer the renowned performance and reliability associated with all DEUTZ engines and powered equipment. They're ideal for use in a wide range of equipment, including:
 - ▲ De-watering pumps
 - ▲ Oil field pumps
 - ▲ Irrigation pumps
 - ▲ Wood chippers
 - ▲ Construction machinery
 - ▲ Sewer vacuums and pumps
 - ▲ Agricultural machinery
 - ▲ Generating sets
 - ▲ Specialty machinery

And, no matter where you are in the world, DEUTZ service is always close by, ensuring maximum availability and service life for your DEUTZ engines and equipment.

| Engine type | | TCD 9.0 L4 |
|--------------------|-------------------------|-------------------|
| No. of cylinders | | 4 |
| Bore/stroke | mm in | 135/157 5.3/6.2 |
| Displacement | l cu in | 9.0 550 |
| Max. nominal speed | min ⁻¹ rpm | 2100 |

| Engine type | | TCD 9.0 L4 |
|-----------------------------------------------|-------------------------|-------------|
| Power output as per ISO 14396 ¹⁾ | kW hp | 304 413 |
| At speed | min ⁻¹ rpm | 1700-2100 |
| Max. torque | Nm lb/ft | 1710 1261 |
| At speed | min ⁻¹ rpm | 1200 - 1600 |
| Minimum idling speed | min ⁻¹ rpm | 800 |
| Weight as per DIN 70020 Part 7A ²⁾ | kg lb | 808 1781 |

1) Power data without deduction of fan power

2) Without starter/alternator, cooler and fluids but with flywheel and flywheel housing

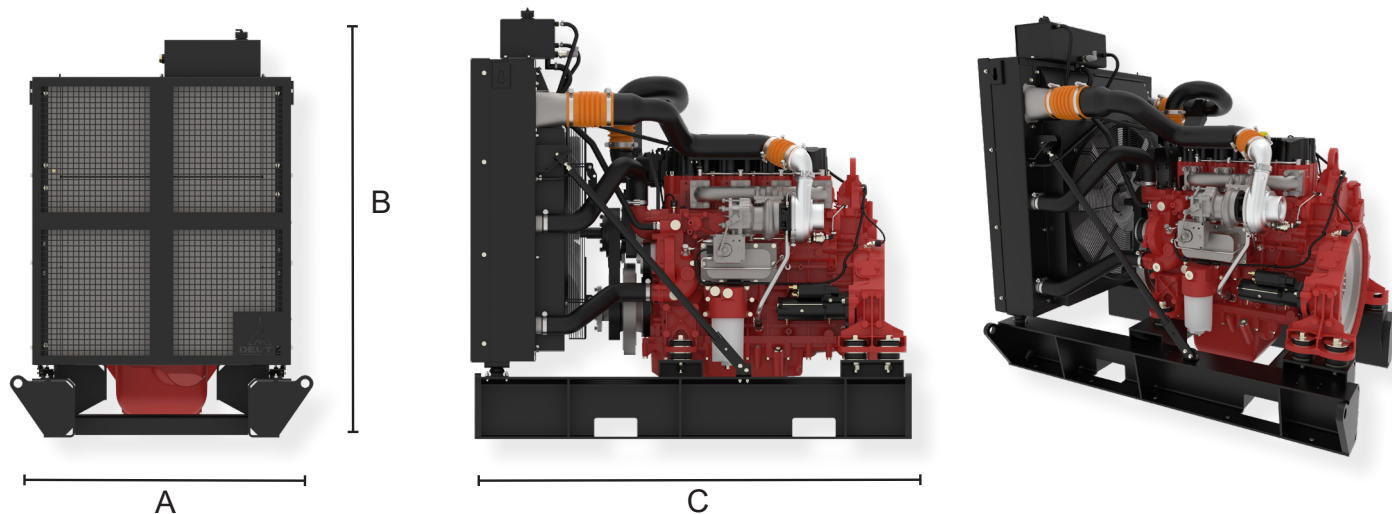

| | | A | B | C |
|-----------------------|-------|-----------|------------|-----------|
| TCD 9.0 L4 - Pedestal | mm/in | 1261/49.6 | 1860/73.24 | 1737/68.4 |



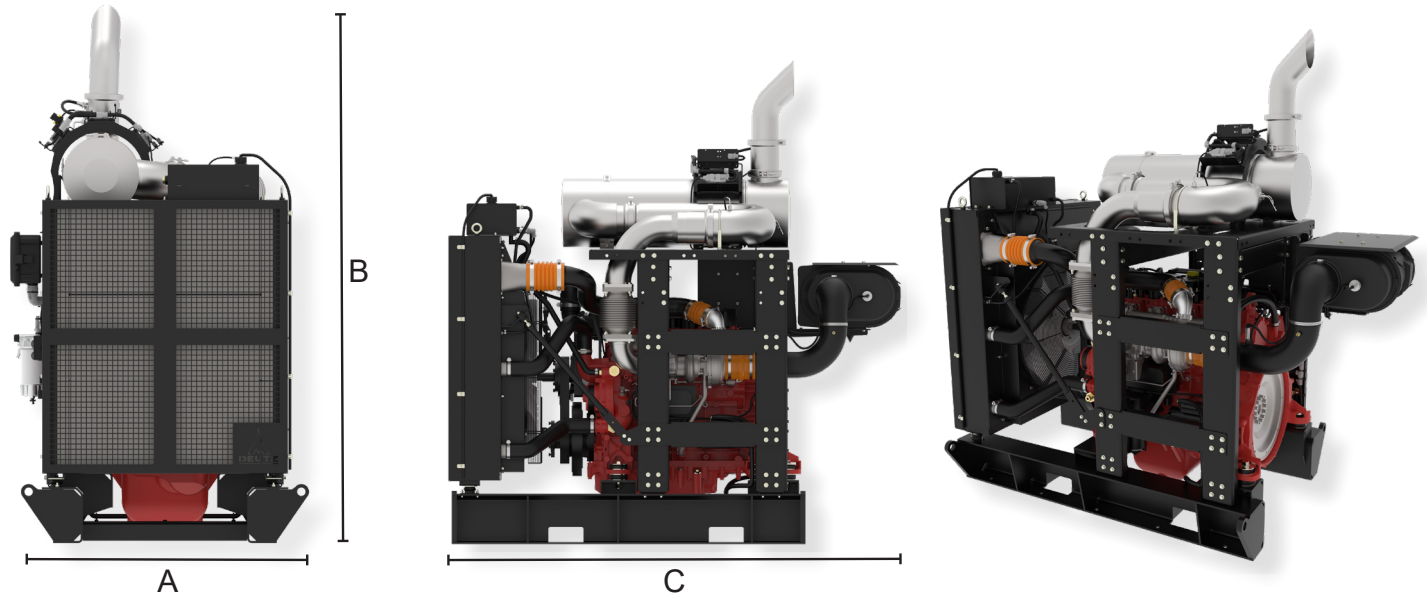

| | | A | B | C |
|-------------------|-------|-----------|-----------|-----------|
| TCD 9.0 L4 - Open | mm/in | 1261/49.6 | 2354/92.7 | 2194/86.3 |

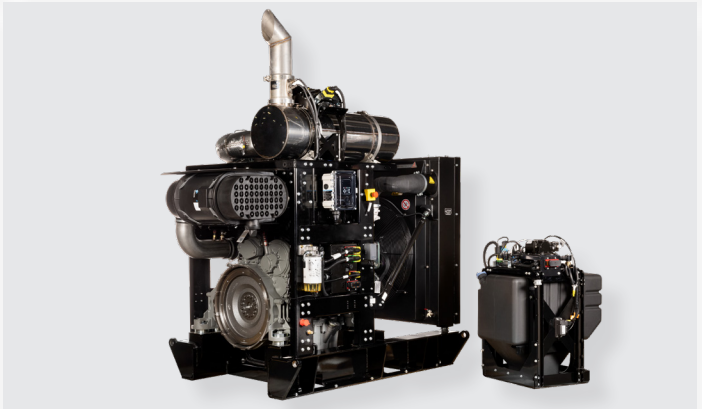

DEUTZ Corporation
 3883 Steve Reynolds Blvd. | Norcross, GA 30093 USA
 Phone: (770) 564-7100 | E-mail: info.usa@deutz.com
 www.deutzamericas.com

The engine company. **DEUTZ**[®]